

Plugging

Abandoned Water Wells

■ *Abandoned wells are potential sources of direct contamination of the groundwater that supplies drinking water.*

■ *Unplugged wells may be a safety hazard to children and animals.*

■ *Mississippi law and regulations require that owners of wells be responsible for plugging wells and test holes.*

A source of clean, safe drinking water is important, and groundwater is our single most important supply in Mississippi. Using groundwater requires wells. Over the years, many wells and test holes around homes, farms, industrial sites, and urban areas have been abandoned without being properly plugged. Not only are these wells potential groundwater-contamination sites, many are a safety hazard to children and animals.

Abandoned wells are potential sources of direct contamination of the groundwater that supplies drinking water. All abandoned wells should be properly plugged to prevent contamination and to eliminate a safety hazard. When a replacement well is drilled, the old well should be plugged. Although plugging an abandoned well takes time and money, these wells are a threat that can no longer be ignored.

Mississippi law and regulations require that owners of wells be responsible for plugging wells and test holes and, therefore, are liable for any water contamination or injury. This publication is provided to help landowners understand how to properly plug a well.

When is a Well Abandoned?

A well is considered abandoned if its use has been permanently discontinued and the pumping equipment is removed or cannot be repaired or replaced.

Plugging Abandoned Water Wells

Proper plugging accomplishes these purposes:

- Restores barriers to contamination;
- Removes safety hazards by closing off tempting openings for children and animals;
- Restores stability to the land surface and geologic formation;
- Removes liability and improves or protects property values.

Plugging a Well Yourself

As a well owner, you may do the work necessary to plug an abandoned well. If you plan to do so, first notify the Mississippi Department of Environmental Quality (MDEQ) and indicate your intent to plug the well and the method you will use. You should also request a well decommissioning form. After the well is plugged, within 30 days you will need to send a copy of the form to the MDEQ. Also send a copy to the Natural Resources Conservation Service (NRCS) for filing. Addresses for these agencies are at the end of this publication.

If you plug a well yourself, you may certify that the well was properly plugged on the decommission form; you are responsible for all information submitted on that form. A local licensed well contractor also may provide this certification.

You can hire a licensed water-well contractor to seal and plug an abandoned well. In some cases this is recommended

because a well contractor has the equipment and an understanding of geologic conditions that affect how the well is plugged.

Determining Proper Procedure

The recommended plugging procedure may vary, depending on your location. All wells in the state require the same plugging procedure other than shallow agricultural wells in the alluvial formation in the Mississippi Delta. This is because of the unique geology of that area.

The plugging procedure described first is for shallow alluvial agricultural wells in the Mississippi Delta. Procedures for plugging an abandoned well that is not in the alluvial formation are given later in this publication. If your well has complex construction or other conditions different from those described, contact MDEQ, NRCS, a licensed well contractor, or your county Extension office for the proper plugging procedures.

Sealing an Abandoned Well: Shallow Alluvial Wells/Delta Only

The following procedures apply to shallow alluvial agricultural wells in the Mississippi Delta only. Deeper wells, whether home, commercial, industrial, public, or other use, must be sealed from bottom to top with grout material, unless otherwise approved by the Office of Land and Water Resources of MDEQ.

Plugging Abandoned Water Wells

Step 1. Prepare the site.

Remove pumping equipment and any foreign objects from the well. Remove debris from around the well site. Dispose of all debris and material in a safe manner.

Step 2. Remove the upper part of the casing.

Remove the casing of the well or cut it off below the surface of the ground. Excavate around the casing to a depth of at least 3 feet and a diameter that is larger than the original bore hole. The minimum casing depth required for sealing a well is 3 feet. Cut the casing off at the desired depth and proceed with abandonment procedure.

Step 3. Disinfect the water in the well.

Disinfect the well with chlorine to kill any existing bacteria in the well or bacteria introduced into the well by the fill material. This prevents contamination of ground-water or nearby water wells. Determine the amount of chlorine needed by measuring the depth of the water and the diameter of the well casing.

Table 1 lists the amount of chlorine product to add to produce a chlorine concentration of approximately 200 milligrams per liter (parts per million), the concentration needed to kill bacteria. The amount of chlorine needed depends on the product concentration. Four concentrations representing various

chlorine products are shown in Table 1. Common unscented household bleach is generally 5.25 percent chlorine.

If a dry chlorine product is used, dissolve it in water before adding it to the well to make certain the material does not settle unused to the bottom of the well.

Example:

Assume a well casing is 12 inches in diameter and is 170 feet deep, with 100 feet of water present, and you want to use 5.25 percent chlorine bleach to disinfect the well. Go to Table 1 and read across from the 12-inch-diameter column to the 5.25-percent column on the right side of the table. You will see 2.88 ounces. This is the amount of chlorine needed to disinfect 1 foot of water in the well. For a well with 100 feet of water, you add 288 ounces of bleach (2.88 times 100 equals 288 ounces), or 2.25 gallons.

Step 4. Fill the water-bearing portion of the well.

To fill the water-bearing portion of the well, you need to find the water level by dropping a weighted string into the well casing (see Figure 1). Drop the weight into the well until it becomes slack. This will give you total well depth. Mark the string with a knot using the top of the casing as a reference. This depth will help determine volume of fill needed.

Plugging Abandoned Water Wells

TABLE 1

Amount of Fill Material and Chlorine to Add for Different Diameter Wells

Diameter of opening (inches)	Amount to fill		Amount to disinfect			
	Volume of well		Liquid chlorine* (ounces)		Dry chlorine* (ounces)	
	gal/ft	cubic ft/ft	5.25%	10%	65%	70%
2	0.16	0.02	0.08	0.04	0.01	0.01
3	0.37	0.05	0.18	0.09	0.02	0.01
4	0.65	0.09	0.32	0.17	0.03	0.03
5	1.02	0.14	0.50	0.26	0.04	0.04
6	1.47	0.20	0.72	0.38	0.06	0.06
8	2.61	0.35	1.28	0.67	0.11	0.10
10	4.08	0.55	2.00	1.04	0.17	0.16
12	5.88	0.79	2.88	1.50	0.24	0.22
14	8.00	1.07	3.91	2.05	0.33	0.31
16	10.44	1.40	5.11	2.67	0.43	0.40
(feet)						
1.5	13.22	1.77	6.47	3.38	0.54	0.50
2.0	23.50	3.14	11.50	6.02	0.97	0.90
2.5	36.72	4.91	17.97	9.40	1.51	1.40
3.0	52.88	7.07	25.88	13.54	2.17	2.02
4.0	94.00	12.57	46.01	24.06	3.86	3.59
5.0	146.90	19.64	71.90	37.60	6.03	5.60
6.0	211.50	28.27	103.50	54.15	8.69	8.07
7.0	287.90	38.48	140.90	73.70	11.82	10.98
8.0	376.00	50.27	184.10	96.26	15.44	14.34
9.0	475.90	63.62	232.90	121.80	19.55	18.15
10.0	587.50	78.54	287.60	150.40	42.13	22.41

* To reach 200 mg/L concentration.
Note: 27 cubic feet = 1 cubic yard

Plugging Abandoned Water Wells

Use sand to fill the well to within 20 feet of the surface (30 feet if underground storage tanks are present). It is not necessary to add additional chlorine because the treated water will help disinfect the sand as it is added. The amount of sand needed depends on the casing diameter and the total well depth.

Example:

A well 12 inches in diameter and 170 feet deep needs 0.79 cubic feet of sand per foot of depth. The well will be filled to a depth of 150 feet (20 feet below the surface); thus, you will need 118.5 cubic feet of sand, which is equivalent to 4.4 cubic yards (118.5 divided by 27 cubic feet per cubic yard equals 4.4 cubic yards of sand). If bagged sand is used, a 50-pound bag contains 0.70 cubic feet of sand. You will need approximately 170 bags (118.5 divided by 0.70 equals 169.3 bags).

Step 5. Plug and cap the well.

After disinfecting the well and filling it with sand as described, you should fill the rest of the well with approved grout materials, which include commercial sodium bentonite clay, neat cement, or bentonite cement mixture. Once the casing is full of grout material, use the same grout material to cap the well. Continue to fill above the casing to a depth of 3 feet below the ground surface with the grout, allowing it to spread out over the diameter of the original bore

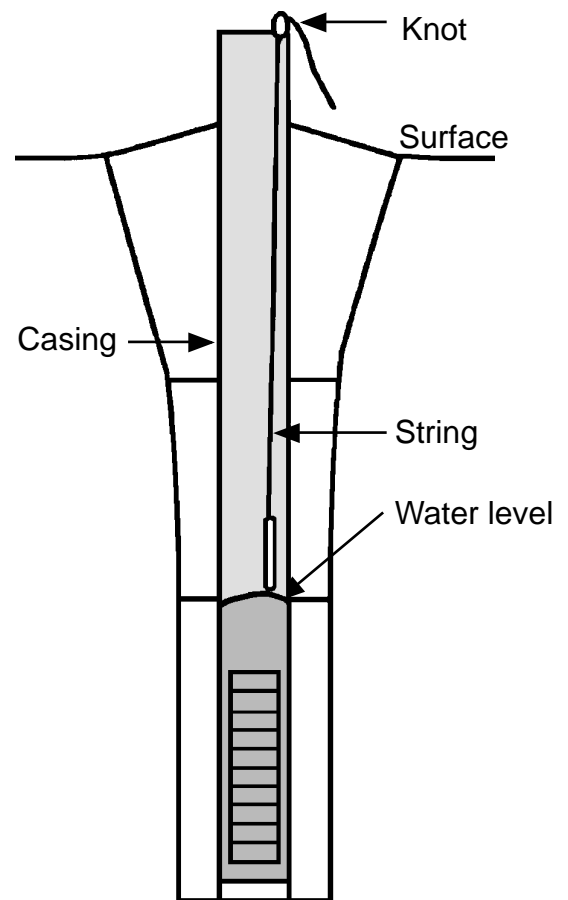

Figure 1.

A weighted string is used to mark the water level.

Plugging Abandoned Water Wells

hole. This is necessary to make sure no contaminants can travel down the outside of the casing to the water table. If the bore hole cannot be identified, make sure the grout material spreads at least 1 ½ feet beyond the edges of the casing in all directions.

Step 6. Complete and file the appropriate forms.

Abandoned wells are an environmental and safety liability. The decommissioning form includes information on the well's location, its physical characteristics, the owner, and the plugging procedure used. The well is not legally plugged unless the decommissioning form is filed.

Plugging Procedure: All Other Wells

As described earlier, abandoned wells that are not irrigation wells in the Delta alluvial formation require different plugging procedures. For these wells, it may be easier to fill the entire casing with approved grouting material. This is a good choice when confining layers or multiple aquifers are present but their exact locations are not known, or for very small-diameter wells where placement of the various layers of fill may be difficult. This approach is also recommended for driven wells.

It will not require as much grouting material as you may think to completely fill a small-diameter well. For example, a

4-inch-diameter well would need only .09 cubic foot per foot of fill (see Table 1). In this case, one 50-pound bag of bentonite will fill 7.8 feet in a well.

If the grouting material is concrete, you will need a small pipe (called a tremie pipe) to apply the grout. This pipe is usually about 3 inches in diameter and in sections 5 to 10 feet long. Cut the bottom of the tremie pipe diagonally. At all times, keep the tremie pipe below the surface of the material being added to prevent dilution and separation of the grout mix (see Figure 2).

Attach the tremie pipe to a hopper box, large funnel, or grout pump at the top of the well. Add more grout to the hopper or funnel, as needed. The mix must be thin enough to flow but thick enough to set properly once in place. The proper ratio for neat cement grout is one 94-pound bag of cement to 7 gallons of water; for cement grout, use 7 gallons of water for each cubic foot of cement-sand grout mix.

Check the volume of material during the plugging process. To keep from applying too much grout, remember how much material is in the tremie pipe at all times and approximately how much depth it will fill. As an example, a 10-foot section of 3-inch-diameter pipe contains nearly half a cubic foot, so 100 feet of pipe would contain 5 cubic feet. Tag or measure the progress of the plugging material as you fill the well, and pump or siphon off any excess water displaced in the well.

Plugging Abandoned Water Wells

In addition to concrete, sodium bentonite clay also can be used to completely fill the casing in these wells.

Sealing Special-Use Wells

If the aquifer is known to contain confining layers or more than one aquifer, pour a plug at each confining layer between each aquifer. If the outside of the casing was not grouted at those locations, the casing should be ripped and grout pumped into the gravel pack to restore a good seal at the confining layer. A licensed water-well driller should perform this work, because it may require special equipment and knowledge about the local geology.

Financial Assistance

Federal cost-sharing assistance to properly seal abandoned wells is available in some areas. To find out if you qualify, contact your local NRCS or Farm Services Agency office.

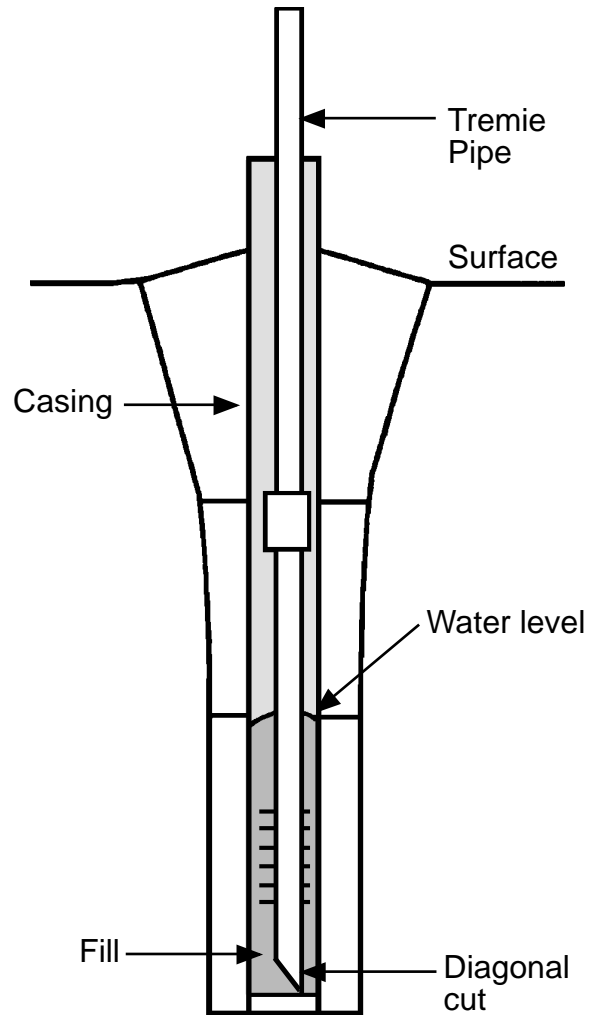

Figure 2.

A tremie pipe is used to carry the grout into the casing to completely fill the well.

Plugging Abandoned Water Wells

For More Information

Regulations on Plugging Abandoned Wells

Mississippi Department of Environmental Quality
Office of Land and Water Resources
P.O. Box 10631, Jackson, MS 39289-0631
(601) 961-5200

Copies of Well Decommissioning Form

Mississippi Department of Environmental Quality
(see above address)

Technical Assistance for Plugging Abandoned Wells

A local certified well driller or county NRCS office; or
Natural Resources Conservation Service
Suite 1321, Federal Building
100 West Capitol Street
Jackson, MS 39269
(601) 965-5205

Financial Assistance

Your county Farm Services Agency or
State FSA Office
P.O. Box 14995
Jackson, MS 39236-4995
(601) 965-4300

For other information about abandoned wells and
water quality, contact your county Extension Office.



www.msstate.edu

Revised by **James G. Thomas**, Leader, Extension Agricultural Engineering, **Dr. Jimmy Bonner**, Assistant Specialist, Mississippi State University Extension Service; from a publication by the Kansas State University Cooperative Extension Service. This publication was developed in cooperation with Mississippi Department of Environmental Quality, Farm Services Administration, and the Natural Resources Conservation Service.

Publication 1994

Mississippi State University does not discriminate on the basis of race, color, religion, national origin, sex, age, disability, or veteran status. Extension Service of Mississippi State University, cooperating with U.S. Department of Agriculture. Published in furtherance of Acts of Congress, May 8 and June 30, 1914. RONALD A. BROWN, Director (rev-1M-11-99)